

# SCHEMA ELETTRICO / ELECTRIC DIAGRAM

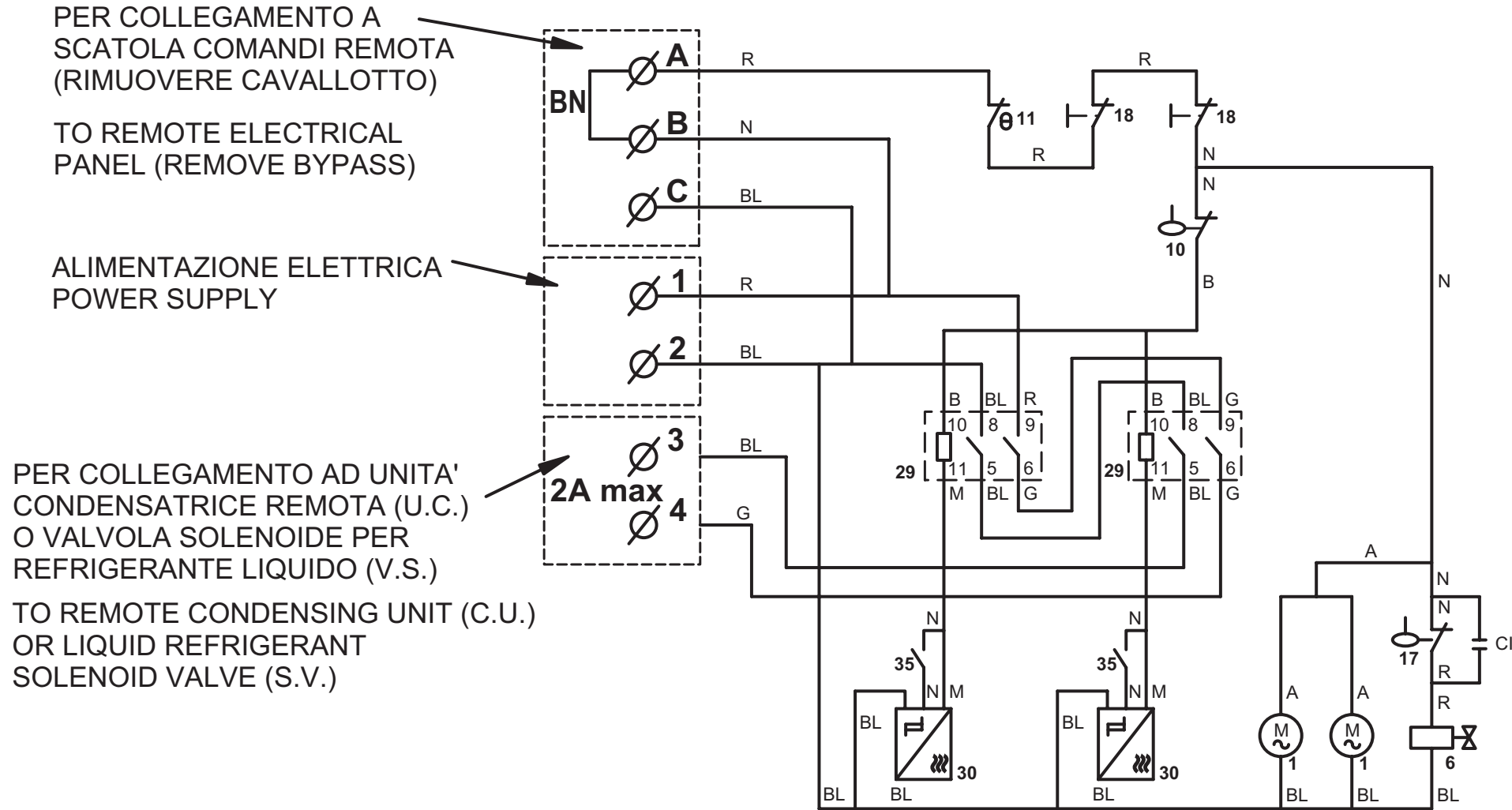

1. MOTORE DEL RIDUTTORE GEAR REDUCTION MOTOR	17. MICRO CONTROLLO LIVELLO ACQUA BACINELLA BASIN WATER'S LEVEL MICRO SWITCH	35. BY-PASS ESCLUSIONE ATTESA WAITING CUTTING OUT BYPASS DA UTILIZZARE SOLO DAL MANUTENTORE TO BE USED BY THE MAINTENANCE PERSONNEL ONLY
6. ELETTROVALVOLA INGRESSO ACQUA BACINELLA BASIN'S WATER INLET VALVE	18. CONTROLLO CONTENITORE PIENO STORAGE BIN CONTROL	
10. MICRO CONTROLLO MANCANZA ACQUA BACINELLA BASIN'S WATER'S LACK MICRO SWITCH	29. RELE' RELAY	
11. TERMOSTATO CONTENITORE BIN THERMOSTAT	30. SENSORE DI ROTAZIONE ROTATION SENSOR	

A = ARANCIO / ORANGE  
B = BIANCO / WHITE  
BL = BLU / BLUE  
G = GRIGIO / GREY  
M = MARRONE / BROWN  
N = NERO / BLACK  
R = ROSSO / RED